



## Features

- 10" Intel® Atom E3845 Fanless Stainless Panel PC
- IP66/67/69K Full Sealed with Anti-Corrosion Enclosure
- Optional IP67 M12 Stainless Connectors
- Optional Cable Gland for External I.O.
- Special Inspection of 100% Waterproof Guarantee
- Wide Temp. -20~50°C Operation Capability
- CE, FCC, VCCI Class B Certified

## Specification

Product		WTP-8B66-10W
Main System	CPU	Intel® Atom E3845 processor
	Graphic	Intel® Gen7 Graphics DX11
	Memory	Single Channel DDR3L 1600 MHz SDRAM Max 8GB
	OS Support	Win 7, Win 7 Pro, Win8.1, Win 10
Display	Size	10" 4:3
	Resolution (pixel)	800 x 600 (SVGA)
	Number of Colors	262K, LVDS 6 bits
	View Angle (H/V)	160(H) / 130(V)
	Brightness(cd/m <sup>2</sup> , nit)	230 nits
	Contrast Ratio	500 : 1 (Typ)
Touch Panel	Type	Full flat resistive touch panel
	Light Transmission	80 ± 5%
	Hardness	4H
	Lifetime	35 million times
Storage & Expansion	Storage	WT 128GB 2.5" SATA SSD
	Expansion	Mini PCIe 52 pin card-edge type x 2 support half/full size
I/O Ports	USB	1 x M12 8pin for USB 1/2, 1 x M12 8pin for USB 3/4
	COM	1 X M12 8pin/ RS-232 1 X M12 8pin/ RS-232/422/485(Default RS-232)
	LAN	1 x M12 8pin
	DC in	1 x M12 5pin DC power connector
	Control Keys	Rear bottom: Power on /off
Power	Power input	DC 9V~36V
	Power adapter	AC100~240V/ 47 ~ 63 Hz / DC output 12V, IP67, 60W
	Power consumption	30.4W
Environmental	Temperature	Operating Temperature -20~50°C Storage Temperature -20~60°C
	Humidity	Operating & Storage: 10 ~ 90%, non-condensing
	Water/Dust resistance	IP66 / NEMA4X / IP69K whole set
Mechanical Characteristics	Housing	Stainless steel (SUS304), chassis type
	Dimensions (Net: mm)	288 x 232 x 58
	Weights (Net: kg))	6.5kg
	Mounting	VESA 100/100, Side mount (M6*2)
Certification	CE/ FCC/ VCCI Class B	

# WTP-8B66-10W

# Stainless Steel Panel PC

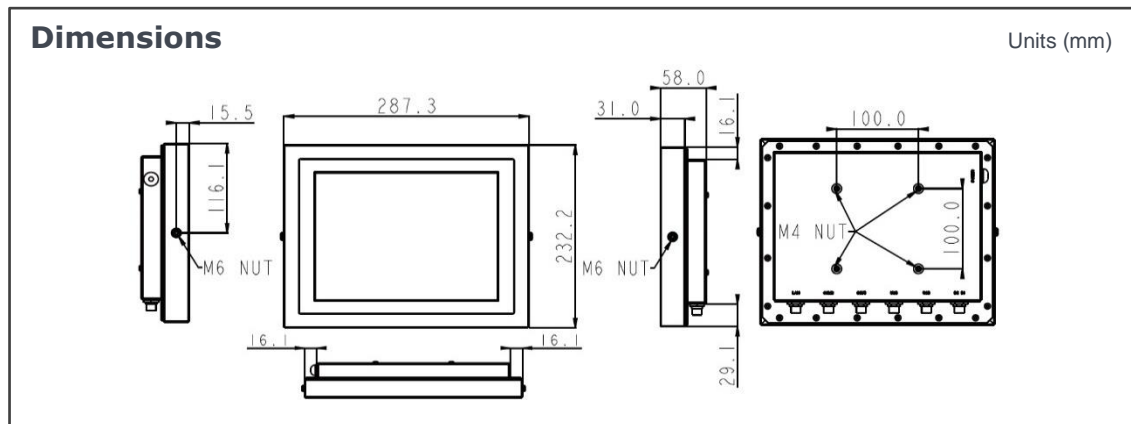

Major Options	
Add on Parts	1. Wireless or Wireless and BT kit (2 ant), 2. Robust Antenna, 3. Full flat PCT touch screen IP69K, 4. Stainless M12 connector, 5. 2 x External LAN, 6. SUS316 enclosure, 7. IP67, 8. Cable Gland for External I.O.
Add on Cable	1. Waterproof COM cable x 1, 2. Waterproof USB cable x 1, 3. Waterproof LAN cable x1
Optional kits	1. Wall mount/ Table mount bracket
Customization	1. Sunlight readable optical bonding, 2. COM + power 5V / 12V, 3. TPM Module , 4. 1000 nits high brightness LCD, 5. LCD auto dimming, 6. Super dimming, 7. Barcode reader , 8. XGA LCD panel, 9. USB 3.0

## Order Information

Item	Cooling	Description
WTP-8B66-10W	Fanless	10" E3845/wide temp. 2G RAM/ 128G SSD/ full flat R-touch



- ① Giga LAN
- ② USB 1/2
- ③ USB 3/4
- ④ COM x 2
- ⑤ DC-in
- ⑥ Power on/off

