

# WMP-196V

## 19" Core i High Performance Medical Panel PC



### Key Features

- Front full flat resistive touch with IP65 rating
- Anti-bacteria plastic housing
- Medical 60601-1 3<sup>rd</sup> edition certification
- 19" 5:4 SXGA 1280x1024 350 nits LCD with LED backlight
- Intel 3<sup>rd</sup> Generation (Ivy Bridge) Core i7/i5/i3 CPU
- PCI-E/PCI expansion and two mini-PCIe sockets
- Low noise variable speed fan and HDD anti-vibration design
- Optional projected capacitive multi-touch screen (10 fingers)
- Optional internal battery pack for 20 minutes operating
- Optional WLAN, Webcam, Bluetooth and RFID reader
- Customization for 4KV LAN/COM/USB isolation card

### Main System

<b>CPU</b>	rPGA988B 3 <sup>rd</sup> Generation Intel® Core i7/i5/i3/ Celeron® processor (35W max.)
<b>Chipset</b>	Intel® BD82HM65 PCH
<b>Graphics</b>	Intel HD Graphics HD 4000
<b>Memory</b>	8GB maximum, DDR3 SODIMM x 2, 1066/1333MHz, 2GB/4GB/8GB/16GB
<b>Serial ATA</b>	SATA2 x 2, 300MB/s transfer rate
<b>USB</b>	· External USB 2.0 x 4 (Type A) · Internal 3.3V Socket x 3, 5V Pin Head x 2
<b>COM</b>	x 6 ( external x 2, internal x 4 )
<b>Audio</b>	Realtek ALC262 audio codec, 2+2 watts amplifier
<b>LAN</b>	Marvell 88E8071 Gigabit Ethernet x 2
<b>BIOS</b>	· AMI BIOS, 4M EEPROM · RTC wake up / Wake on LAN / Power on after power failure / PnP / ACPI
<b>Speaker</b>	2 watts x 2 (front bottom)

### LCD Panel

<b>Size</b>	19" 5:4
<b>Resolution</b>	SXGA 1280 x 1024
<b>Brightness</b>	350 nits
<b>Contrast</b>	1000:1
<b>Color numbers</b>	16.7M (6-bit x 3 + Hi FRC)
<b>Viewing angle</b>	170 (H) / 160 (V)
<b>Response time</b>	5 ms (R + F)
<b>Backlight</b>	LED, 50,000 hours life time

### Touch Panel

Technology	5-wire resistive touch (default)	Projected capacitive touch (option)
<b>Type</b>	Front full flat touch panel	Front full flat 10 point touch panel
<b>Transparency</b>	> 78% (at 550 nm wavelength)	90% ± 3%
<b>Hardness</b>	3H	7H
<b>Durability</b>	Knock 35 million times	Knock 100 million times

### Storage & Expansion

<b>HDD</b>	2.5" SATA HDD drive bay x 1 + anti-vibration kit, 320GB / 500GB
<b>Expansion slot</b>	· PCI-E (x16) x 1 (or PCI x 1) (Optional) · Card size: 100 x 155 x 18/0.5 mm or 68 x 220 x 18/0.5 mm · Mini PCIe x 2 (52 pin card-edge type)

### I/O & Control Keys

<b>USB</b>	USB 2.0 x 4
<b>COM</b>	DB-9 x 2 (RS232, RS232/422/485 <w/ auto flow control>)
<b>LAN</b>	RJ-45 x 2, Gigabit
<b>Video-out</b>	DVI-I x 1
<b>Audio</b>	Line-out, Microphone-in (3.5 mm phone-jack)
<b>Power input</b>	DC-in x 1, 6V~32V
<b>Control keys</b>	· Front side, projected capacitive type · Power on/off, Brightness, Audio volume, Backlight on/off, Touch on/off

### Power

<b>Power adaptor</b>	External, 100 watts, 90~264V AC in, 12V DC out, medical grade, 1.2m DC cable
<b>Power consumption</b>	75 watts (typical, without any add-ons)
<b>Internal battery (optional)</b>	· Lithium-Ion, 29Wh, for 20 minutes operating (approx.), 2S2P · Charge time: 2 hours (system off), 3.5 hours (system on)

### Mechanical & Environmental

<b>Housing</b>	· Front: Full flat design / Touch (standard), Glass (Customization) · Rear: Plastic + I/O cover w/ antibacterial treatment
<b>Color</b>	· Housing: White · Control key icons: Grey ( Panton no. Cool grey 8C )
<b>IP rating</b>	IP65 – front side
<b>Cooling</b>	Variable speed smart fan design, < 30 dB (typical)
<b>Mounting</b>	VESA 75 x 75 / 100 x 100 mm
<b>Kensington lock</b>	Yes, x 1 at bottom
<b>Dimension</b>	450 x 420 x 85.3 mm (W x H x D, w/o stand)
<b>Weight (net)</b>	7.5 Kg (approximate, w/o power adaptor)
<b>Temperature</b>	· Operating – 0°C~40°C · Storage – -20°C~60°C
<b>Humidity</b>	Operating & storage – 10%~90%, non-condensing
<b>Regulatory</b>	· FCC-B, cUL, CE, VCCI · Medical 60601-1 3 <sup>rd</sup> edition (EN 60601-1:2006, ANSI/AAMI ES60601-1:2005, CAN/CSA C22.2 No. 60601-1:08)

# WMP-196V

19" Core i High Performance Medical Panel PC

## Outline Dimension

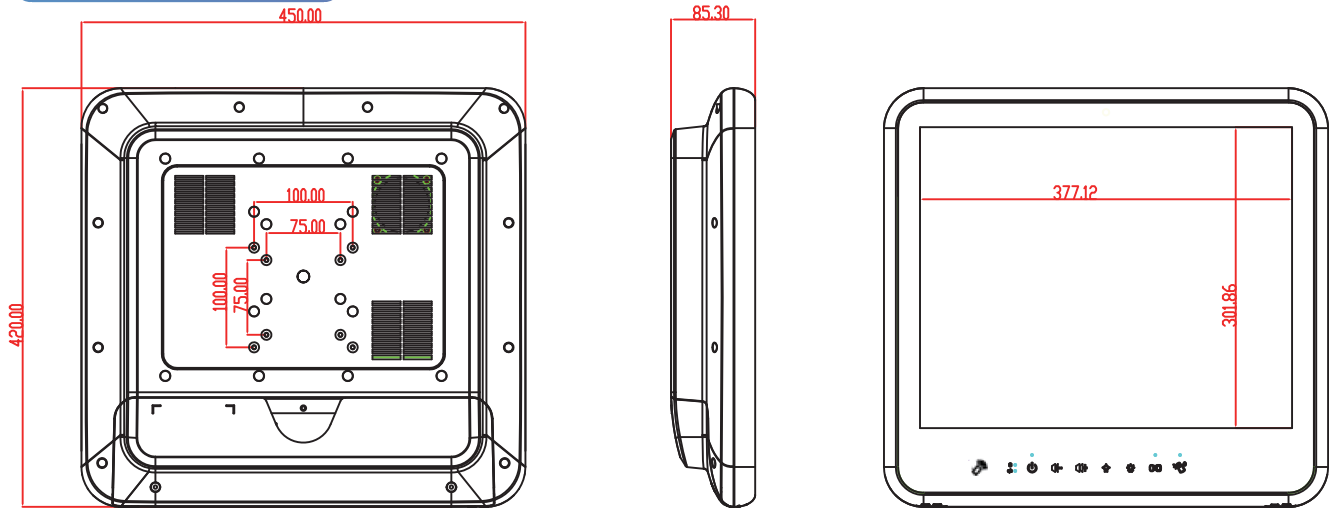

## Packaging / Options / Customization

### Packaging Options

- System, power adaptor, AC power cord, DVD (drivers & manual)
- WLAN – 802.11 a/b/g/n mini PCIe module w/ internal antenna x 2
  - 802.11a/b/g/n dual-band 2T2R with Bluetooth
  - Webcam (2M pixel, USB)
  - Battery pack
  - RFID reader (13.56Hz, USB)
  - Video Graphic card (PCI-E x 16)
  - PCI-E x16 or PCI raiser card
  - Power adaptor w/ 2.4m or 3.6m DC cable
  - Anti-bacteria desktop stand (metal, white)
  - Microphone on I/O cover
  - PoE card
  - AG Film
  - Projected capacitive multi-touch

### Customization

- Add extra two COM ports
- 4KV Isolation Card x 1 (Isolation COM x 2, Isolation LAN x 1, Isolation USB x 1)
- Change touch to glass
- High Speed USB 3.0 x 2
- TPM module

### 4KV Isolation card



## I/O Connectors

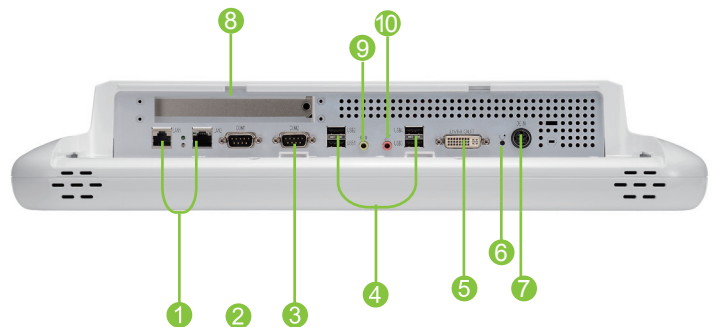

- |                 |                       |
|-----------------|-----------------------|
| 1 LAN x 2       | 8 PCI-E/PCI expansion |
| 2 RS232/422/485 | 9 Line-out            |
| 3 RS232         | 10 Microphone-in      |
| 4 USB x 4       |                       |
| 5 DVI-I         |                       |
| 6 Reset         |                       |
| 7 DC-in         |                       |



## Ordering Information

- CPU: Core i5 2.5G (default) / Core i7 2.2G / Core i3 2.4G
- Memory: 2G / 4G / 8G / 16G
- HDD: 320G / 500G
- Power adaptor: 1.2m / 2.4m / 3.6m DC cable
- WLAN: None / x 1
- Bluetooth + WLAN: None / x 1
- Battery pack: None / x 1
- RFID reader: None / x 1
- Expansion: None / PCI-E / PCI
- Webcam: None / x 1
- Desktop stand: None / x 1
- PoE: None / x 1
- AG Film: None / x 1
- Touch: Projected capacitive multi-touch / 5 wire resistive touch



Web: [www.wincomm.com.tw](http://www.wincomm.com.tw)

Contact: [sales\\_support@wincomm.com.tw](mailto:sales_support@wincomm.com.tw)

### Wincomm Corporation

3F, NO. 14, Prosperity Road II, Science-Based Industrial Park,  
Hsinchu, Taiwan 30078, R.O.C

Tel : +886 3 578 0000 Fax: +886 3 578 0295