



### Key Features

- Intel Broadwell Fanless Medical Panel PC
- 15.6" Wide 16:9 1366x768 LED panel
- P-CAP multi-touch with 10 fingers
- Medical UL60601-1 3rd edition certification
- Anti-bacteria (MRSA) plastic housing
- Friendly design of front function hot-keys
- Optional PCI-E/PCI expansion slot
- Optional 4KV LAN/COM/USB isolation I/O
- Optional built-in battery pack



### Outline Drawing

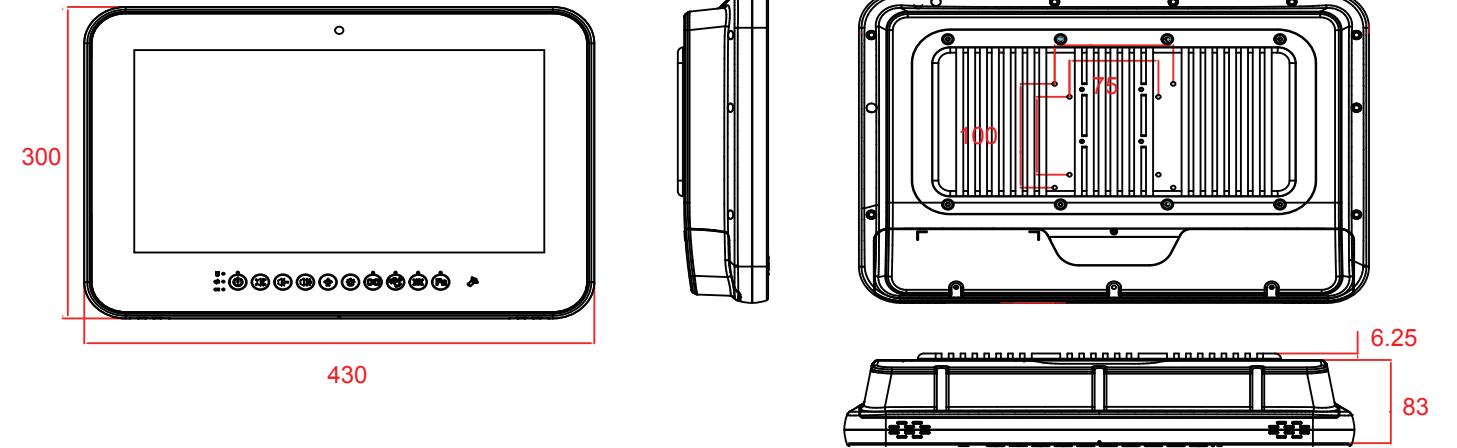

### Main System

<b>CPU</b>	FCBGA1168 5th generation Intel® Core i7/i5/i3 processor (15W max.)
<b>Chipset</b>	SoC
<b>VGA</b>	Intel® integrated HD Graphics 5500 by CPU
<b>Memory</b>	Two 1600 MHz DDR3L SODIMM socket support dual Channel, non-ECC, up to 16GB
<b>Speaker</b>	2 W x 2

### LCD Panel

<b>Size</b>	15.6" wide 16:9
<b>Resolution</b>	1366x768
<b>Color numbers</b>	16.7M colors (RGB 6-bit + Hi FRC)
<b>Viewing angle</b>	170 (H) / 160 (V)
<b>Contrast</b>	500:1 (Typ)

### Touch Panel

<b>Type</b>	Full flat projective capacitive touch panel (10 fingers)
<b>Light transmission</b>	90% ± 3%
<b>Hardness</b>	7H pencil, pressure 750g/45°
<b>Life time</b>	100M times

### Storage & Expansion

<b>HDD</b>	2.5" SATA HDD drive bay x 1 ,
<b>Expansion slot</b>	<ul style="list-style-type: none"> <li>• PCI-E (x4) expansion slot x 1 (25W max, can't co-exist with isolated module)</li> <li>• Card size: 100mm (W) x 160mm (D) x 14mm (H)</li> <li>• Mini-PCIe x 2 (52 pin card-edge type)</li> </ul>

### I/O & Power & Control Keys

<b>USB</b>	USB 3.0 x 2 , USB 2.0 x 2 (Default)
<b>COM</b>	RS232 x 1, RS232/RS422/RS485 x 1 (RS-485 auto flow support)
<b>LAN</b>	RJ-45 x 2, Gigabit
<b>Video-out</b>	DP x 2
<b>Audio</b>	Line-out, Microphone-in (3.5 mm phone-jack)
<b>Power input</b>	DC-in x 1, DC 7~32V input (9~28V with battery pack)
<b>Power adaptor</b>	AC input 90 ~ 264V / 47~63 Hz / DC output 12V, medical grade, 1.2m DC cable
<b>Power consumption</b>	78.2 W ( MAX. loading without adapter )
<b>Control keys</b>	Power, audio volume, brightness, backlight on/off, Clean me, webcam (disable), programmable button

### Mechanical & Environmental

<b>Housing</b>	<ul style="list-style-type: none"> <li>• Front: Full flat design / Touch (standard), Glass (Customization)</li> <li>• Rear: Plastic + I/O cover w/ antibacterial treatment</li> <li>• Anti-bacteria (MRSA)</li> </ul>
<b>IP rating</b>	IP65 – front side, IPx1 whole system
<b>Cooling</b>	Fanless
<b>Dimension</b>	430 (H) x 300 (V) x 83 (T) (mm x mm x mm)
<b>Weight (net)</b>	5 kg (w/o power adapter)
<b>Temperature</b>	Operating : 0°C~35°C (chamber) Storage : -20°C~60°C
<b>Humidity</b>	Operating & storage – 10%~90%, non-condensing
<b>Regulatory</b>	<ul style="list-style-type: none"> <li>• FCC/CE/VCCI Class B</li> <li>• cULus Mark/UL60601-1</li> <li>• EN60601-1 approved / ISO 14971 / IEC-62133</li> <li>• Energy star 6.1 compliance</li> </ul>

### Options

802.11 a/b/g/n WLAN module (Mini PCIe)
802.11 a/b/g/n WLAN + Bluetooth 4.0 module (Mini PCIe)
5M pixel AF webcam module (USB)
Battery pack
PCI-E x 4 riser card
Power adaptor w/ 2.4m or 3.6m DC cable
Anti-bacteria desktop stand (white, L type)
Equipotential terminal pin
AG film
TPM v1.2 module
mSATA module
4KV Isolation Card x 1 (Isolation COM x 2, Isolation LAN x 1, Isolation USB x 1)

### Customization

USB 5,6 or COM 3,4
Tempered glass
RFID reader (13.56Hz) (USB)

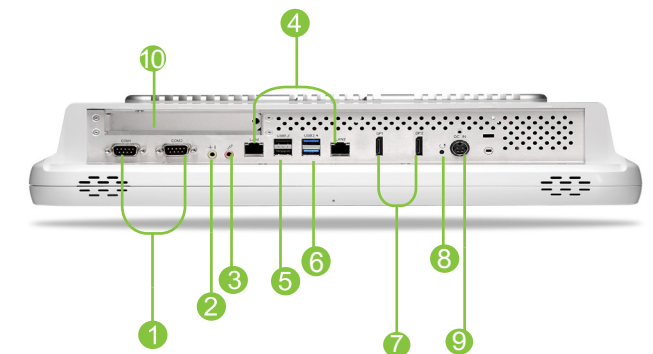

- ① COM x 2
- ② Line-out
- ③ Microphone-in
- ④ LAN x 2
- ⑤ USB 2.0 x 2
- ⑥ USB 3.0 x 2
- ⑦ DP x 2
- ⑧ Reset
- ⑨ DC-in
- ⑩ PCI-E/PCI expansion

### Ordering Information

WMP-15A (i5)	15" FANLESS	i5-5200U/4G/500G/P-CAP
WMP-15A (i7)	15" FANLESS	i7-5500U/4G/500G/P-CAP

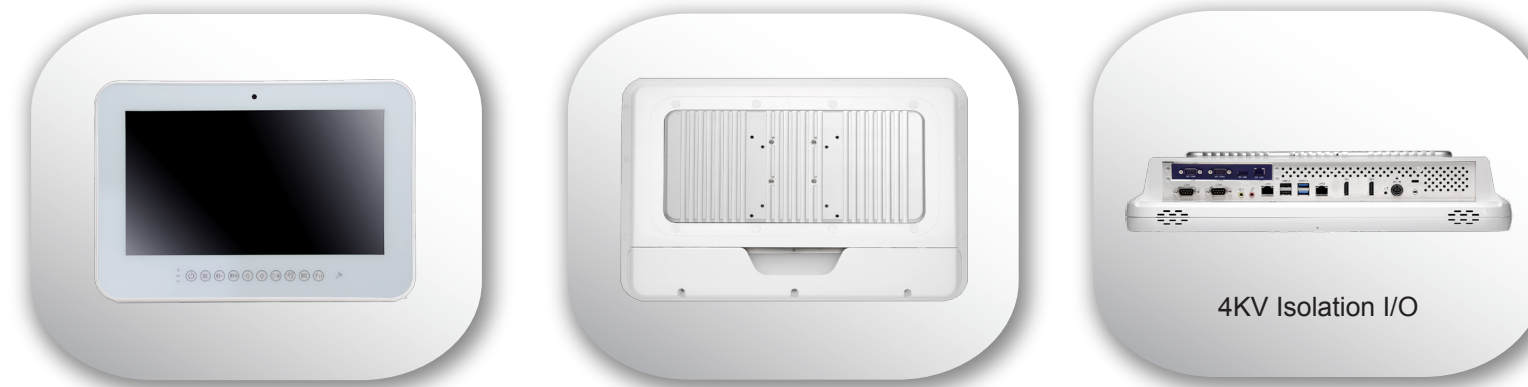

4KV Isolation I/O